

TIGER 1050 SE PANNIER SYSTEM

Tiger 1050 SE Pannier System

Note:

- The pannier is marked in three positions around the lock barrel. To lock, release or open the panniers the key slot must align with the corresponding markings around the barrel as shown.

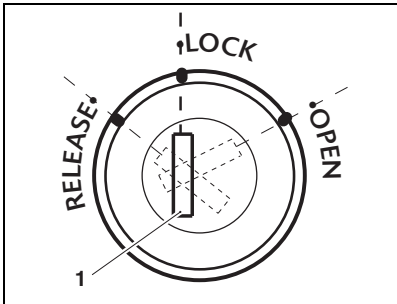

1. Key slot (shown in the LOCK position)

Pannier Operation

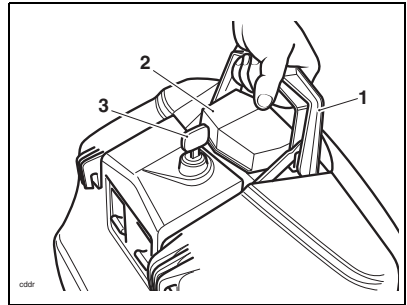

1. Carrying handle
2. Press plate
3. Key

To unlock the lid of the pannier, insert the key and turn it to the open position, then press down on the press plate. The lid can then be opened.

To lock the lid of the pannier, turn the key to the open position, press down on the press plate and close the lid then release the press plate. Turn the key to the central LOCK position and remove it.

If the key cannot be removed, repeat the lid locking procedure making sure the lid is properly closed and the press plate has returned to the fully locked position.

 **Warning**

The maximum safe load for each pannier is 5 kg (11 lbs). Never exceed this loading limit as this may cause the motorcycle to become unstable leading to loss of control and an accident.

 **Warning**

Incorrect loading may result in an unsafe riding condition leading to an accident.

Always ensure any loads carried are evenly distributed on both sides of the motorcycle. Ensure that the load is correctly secured such that it will not move around while the motorcycle is in motion.

Always check the load security regularly (though not while the motorcycle is in motion) and ensure that the load does not extend beyond the rear of the motorcycle. Never exceed the maximum vehicle loading weight of 200 kg.

This maximum loading weight is made up from the combined weight of the rider, passenger, any accessories fitted and any load carried.

 **Warning**

After fitting or removing the panniers, operate the motorcycle in a safe area free from traffic to gain familiarity with the new handling characteristics. Operation when not familiar with the new characteristics of the motorcycle may result in loss of control and an accident.

 **Warning**

Never ride an accessory equipped motorcycle (especially those fitted with a pannier system) at speeds above the legal speed limit or at a speed inappropriate for the circumstances.

Speeds in excess of 130 km/h (80 mph.) should not be attempted on an accessory equipped motorcycle even where the legal speed limit permits this. The presence of accessories will cause changes in the stability and handling of the motorcycle.

Failure to allow for changes in motorcycle stability may lead to loss of control or an accident.

Remember that the 130 km/h (80 mph.) absolute limit will be reduced by the fitting of non-approved accessories, incorrect loading, worn tyres, overall motorcycle condition and poor road or weather conditions.

Warning

This motorcycle must not be operated above the legal road speed limit except in authorised closed course conditions.

Warning

Only operate this Triumph motorcycle at high speed in closed-course on-road competition or on closed course racetracks. High speed operation should only be attempted by riders who have been instructed in the techniques necessary for high speed riding and are familiar with the motorcycle's characteristics in all conditions.

High speed operation in any other circumstances is dangerous and will lead to loss of motorcycle control and an accident.

To Remove Each Pannier

Note:

- **The same procedure can be followed to remove and mount the left hand or the right hand panniers.**

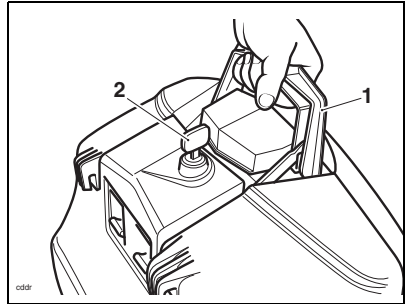

- 1. Carrying handle**
- 2. Key**

To unlock and remove the pannier from the pannier rail, insert the key into the lock. Lightly press down on the carrying handle and turn the key anti-clockwise then release the carrying handle. Lift the carrying handle to its fully raised position and lift the pannier free from the pannier rail.

To Install Each Pannier

Warning

The left and right hand panniers are not interchangeable. Fitment of either pannier to the incorrect side will cause the motorcycle to become unstable leading to loss of motorcycle control and an accident.

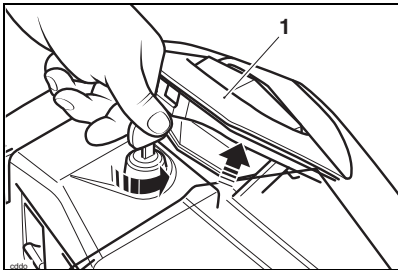

1. Carrying handle

Insert the key into the lock. Lightly press down on the carrying handle and turn the key anti-clockwise then release the carrying handle. Lift the carrying handle to its fully raised position.

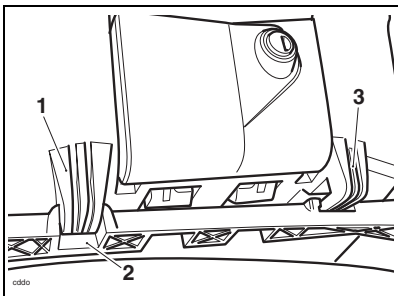

1. Front fixed hook (pannier)
2. Front locating point (pannier rail)
3. Rear fixed hook

Position the pannier against the pannier rail and engage the front fixed hook of the pannier with the front locating point on the rail. The rear fixed hook should be above the pannier rail at this point.

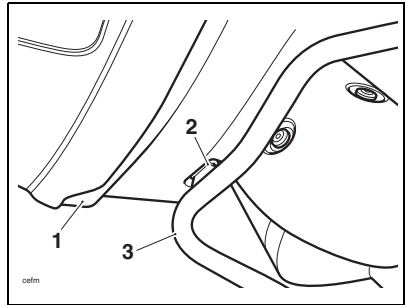

1. Pannier
2. Locating cup
3. Locating bracket

Lower the rear fixed hook to the pannier rail ensuring that the end of the locating bracket fits into the locating cup moulded into the side of the pannier.

Lock the pannier to the rail by turning and holding the key anti-clockwise and at the same time pressing the carrying handle to the fully closed position. Turn the key to the central LOCK position and remove it.

This page intentionally left blank